

Design Guide



CLICKDECK PROFILES (JOIST / BEARERS)



28 Profile

55 Profile

110 Profile

CLICKDECK SUPPORTS



Pedestal supports

Post supports

CONTENTS:

Specifications

- **Span Tables**
- **Component layouts**
- **Connection details**
- **Deck Supports / Post Support**
- **Special Layouts / Fixing Guide**
- **Breaker board / Picture frame layout**
- **Paver Installation**
- **Curved frame layout**
- **Handrail connection detail.**

Cutting:

We recommend an aluminium or multi material blade used in a dropsaw or grinder.

Safety:

Please ensure all PPE is worn

Foundations:

Ensure appropriate structural foundation is made under each pedestal or post to support deck loading.

Engineering:

General span calculations and engineering is available through us to assist with permits ect. Site specific engineering may be required which can be carried out by a licenced structural engineer.

Fastners:

All fixings shall be either stainless steel or B8 coated screws.

Aluminium contact points:

Aluminium bolted to concrete - Separated with plastic or EPDM packer (Minimum 2mm clearance to concrete).

Aluminium encased in concrete - Concrete shall not be "rapidset" or contain lime and aluminium to be fully separated by corrosion resistance paint or similar.

Aluminium to steel - Steel to be HDG and packer to separate contact point.

Aluminium to natural ground - 5mm clearance.

Loadings:

Standard loading for residential decks under 1m = 2kpa Live load and .2kpa dead load have been used. For all additional loading requirements contact us for a tailored design.

Project Design:

Installer shall verify all measurements and install as per relevant building code. This information is for guidance only and does not overrule building codes.

Attention -

Do not overtighten hex screws recomended torque 39 Nm

Aluminium Profiles - Joist / Bearers



Powdercoated Aluminium Sections

Standard Lengths : 2.4m, 3.6m, 4.8m, 6m

Lowest height acheivable = 30mm (Top of frame)

SURFACE COMPATIBILITY



- All brands of composite decking
- Natural Timber
- Structural Tiles
- Synthetic Turf
- Yellow Tounge Flooring
- Blueboard and other structural boards
- Many others ...

JOIST ORIENTATION:

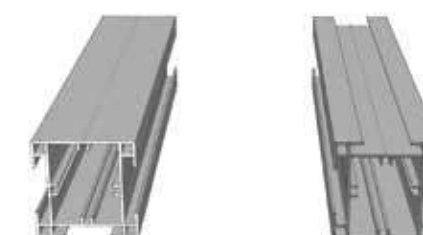

Flat side UP

Decking

Flat side DOWN

Tiling/Paving

CAN BE BUILT OVER:

- Natural Ground
- Concrete
- Existing Tiles / Pavers
- Waterproof areas

Site/load specific engineering available on request

FORM 126 COMPLIANT (VICTORIA) FORM 15 COMPLIANT (QLD)

Standard Residential deck loading - Class A -
- 2Kpa Live Load , 0.2Kpa Dead Load , 1.8 KN Point Load*

Profile	Joist Span (recommended)	Bearer Span (recommended)	Cantilever (max)
28 x 50	600mm	600mm	N/A
55 x 55	1200mm	1200mm	250mm
110 x 45	1900mm	1750mm	400mm

Barrason's Engineers
Structural & Civil Design



Structural Assessment

Project: Aluminium Subfloor System **Ref No.** 2207264 CAN-001
From: Andrew Barraclough **Date:** 20/02/2023

Attention **Company** **Email**
Exolux Modular Subfloor Systems

Re: Clickdeck Decking System

I, Andrew Barraclough, certify that we have carried out a design check for the aluminium subfloor elements' sections of 28x50, 55x55, and 110x55. We confirm that the nominated aluminium profile sections and connections can sustain the design loads during the stages (Refer: 'Clickdeck Residential Span Table' and 'Clickdeck Commercial Span Table') for the nominated structural purposes.

Kind Regards,

Andrew Barraclough

Dr Andrew Barraclough
BEng MEng PhD FIEAust CPEng NER RBP (EC 46301)
Barrason's Engineers, Principal Engineer

Notes:

- This consultant advice notice does not authorise any extension of time or cost variation.
- Should the contractor deem that this notice constitutes an extension of time or cost variation, then they are to submit a claim in writing to the project manager and obtain approval prior to undertaking the nominated works.
- This communication may contain information that is privileged, confidential and/or exempt from disclosure under applicable law. If you are not the intended recipient, you are hereby notified that any disclosure, copying, distribution, or use of the information contained herein is prohibited. If you receive this transmission in error, please immediately contact the sender and destroy the material in its entirety, whether in electronic or hard copy format.

Barrason's Engineers

A: Lvl 2-3, 2 Pacific Promenade, Pakenham, Vic, 3810

P: (03) 5940 2638

E: admin@barrasons.com.au

W: www.barrasonseengineers.com

ABN: 96 635 681 300

SPAN TABLES

2.5 Kpa / 1.8 PL - Standard Residential
(Standard loading - ~3 People per SQM)

Notes: Vibration check for 1.8 KN PL <2mm

JOIST SPACING: 450mm

JOISTS		
PROFILE	SPAN	CANTILEVER
28x50	600/700*	200
55x55	1050/1200*	300
110x50	1900/2100*	500

28x50 - BEARER		
JOIST SPAN	BEARER SPAN	CANTILEVER
600	600/700*	200
1000	550/650*	200
1200	550/650*	200
1500	550/650*	150
1900	550/650*	150
2100	500/650*	150

55x55 - BEARER		
JOIST SPAN	BEARER SPAN	CANTILEVER
600	1200/1200*	300
1000	1150/1200*	300
1200	1100/1200*	300
1500	1050/1150*	250
1900	950/1050*	250
2100	950/1000*	200

110x50 - BEARER		
JOIST SPAN	BEARER SPAN	CANTILEVER
600	2400/2600*	500
1000	2150/2400*	500
1200	2050/2200*	500
1500	1900/1950*	400
1900	1700/1750*	400
2100	1600/1650*	400

- Minimum back span length to be 4 times of the overhang length
- *Continuous Span

3.5 Kpa / 2.7 PL - (Commercial)
(Standard loading)

JOIST SPACING: 450mm

JOISTS		
PROFILE	SPAN	CANTILEVER
28x50	450/500*	200
55x55	1000/1200*	300
110x50	1900/2100*	400

28x50 - BEARER		
JOIST SPAN	BEARER SPAN	CANTILEVER
500	450/550*	250
1000	450/550*	150
1200	450/550*	150
1500	450/550*	150
1900	450/550*	100
2100	450/550*	100

55x55 - BEARER		
JOIST SPAN	BEARER SPAN	CANTILEVER
500	1100/1200*	300
1000	950/1150*	300
1200	950/1100*	250
1500	950/1000*	200
1900	850/850*	200
2100	850/850*	200

110x50 - BEARER		
JOIST SPAN	BEARER SPAN	CANTILEVER
500	2100/2300*	400
1000	1900/2000*	400
1200	1850/1850*	300
1500	1650/1650*	300
1900	1500/1500*	250
2100	1400/1400*	250

- Minimum back span length to be 4 times of the overhang length
- *Continuous Span

COMPONENT LAYOUT

55PROFILE (SHOWN)

TYPICAL BEARER/JOIST LAYOUT



28 Profile

55 Profile

110 Profile

BEARER
(Supports the joist)



JOIST
(Supports the deckboard)



HOLD DOWN CLIPS

(Holds the Joist to the bearer)
(1 clip per connection - 25 per Pack)



PERIMETER JOIST
(Braces / links the joists together)



PEDESTAL / POST SUPPORTS

(Height adjustable deck supports)



CORNER BRACKET

(Used to make 90 degree angles)
(Bent to create any angle)
(1 per connection - 2 per pack)

Installed at the connection of joist to perimeter joist

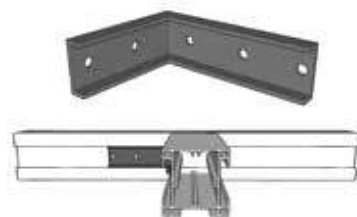

JOINER

(Used to extend the length of the aluminium)
(2 per connection - 6 per pack)
(Only needed if longer than 6m length)



TILE RUBBER STRIP

Only used when installing pavers on deck.
(Rubber strip clicks into joist)

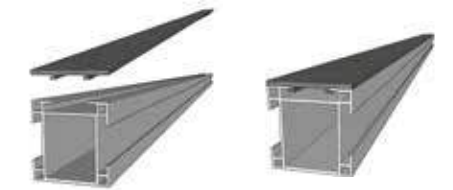

Go to Paver installation section for more information

FASCIA JOIST SUPPORT

(Allows fascia boards to be attached to the deck)
1. Corner bracket installed under perimeter joist
2. 55Profile installed in vertical position

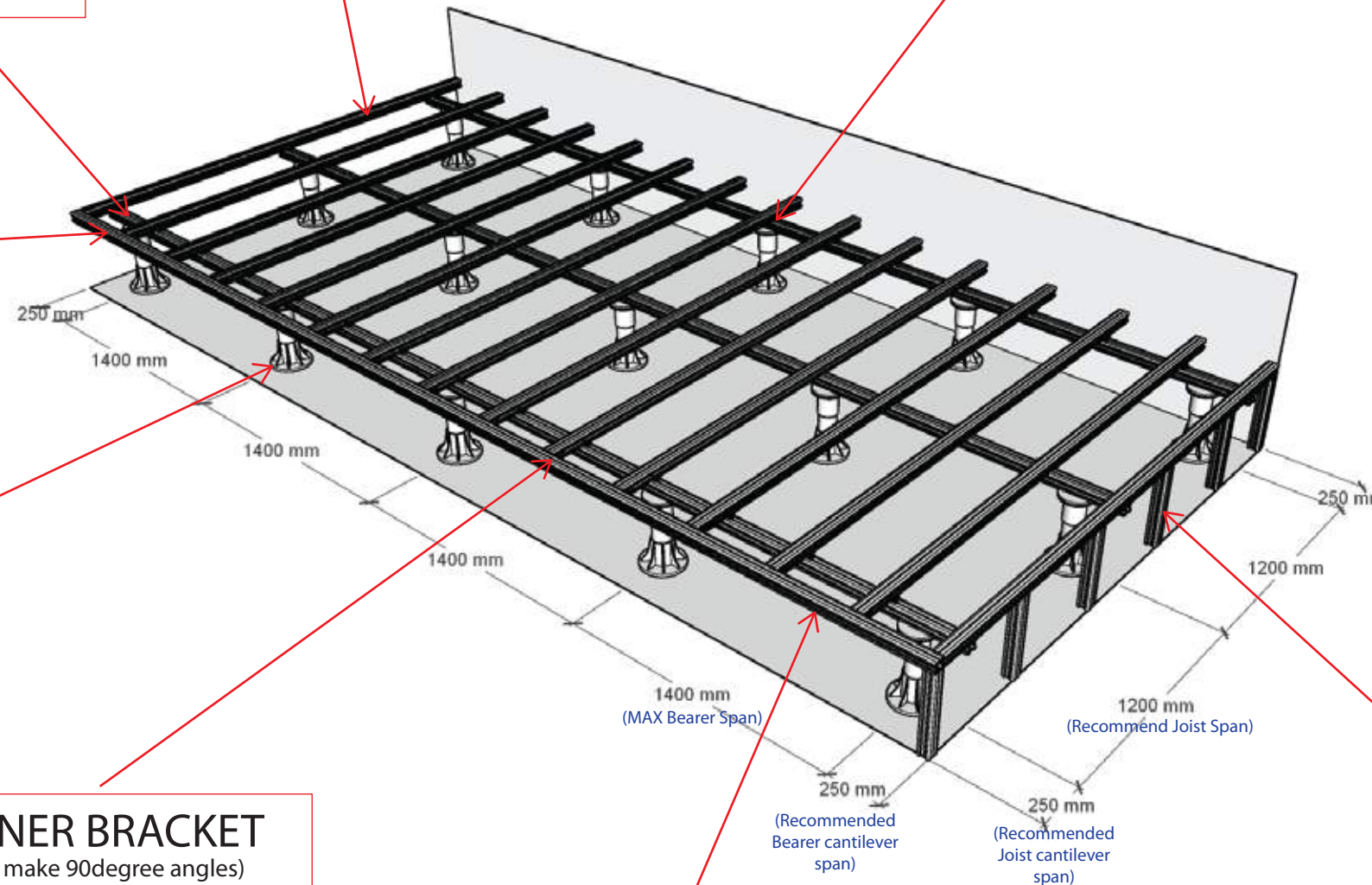
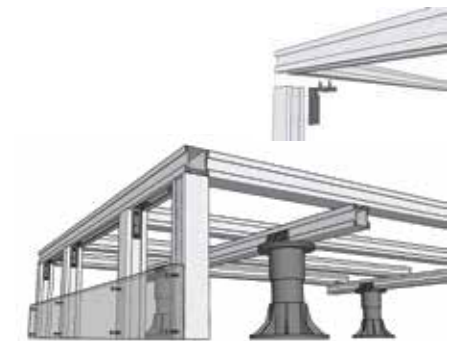

Components



Joiner
(6 Pack)

Used to join / extend the aluminium profiles
2 Joiners per Join on 55mm Profile
4 Joiners per Join of 110mm profile



Hold down Clip
(25 Pack)

Used to fix down the Joists to the bearers



Corner Bracket
(2 Pack)

Used to make 90 degree Joins, can be bent to make various angles.
Also used to make vertical fascia board supports .



Hex Screws
(250 Pack)

Stainless M10 30mm Hex Screw with washer
Used to fix all components together



Post Bracket
(Per bracket)

Post Bracket - Used to support the frame system.
If concreting post in hole - Only 1 bracket at the top is needed
If Bolting down to pad - 2 brackets needed, 1 at top and bottom



Tile Rubber Strip
(Per meter)

Tile Rubber Strip - Used to support structural pavers on our aluminium joist system.



Tile Retaining Clip
(25 Pack)

Tile Retaining Clip - Installed around the perimeter of the tile deck to stop Tile/Pavers from moving.

Pedestals



Adjustable Pedestals

Pedestal Heights

Model Number	Pedestal Range <small>(All measurements are in millimeters)</small>	Finished Floor Height		
		<small>Including (28profile) (Deckboard/Joist/pedestal)</small>	<small>Including (55profile) (Deckboard/Joist/pedestal)</small>	<small>Including (55Profile) (Deckboard/Joist/Bearer/pedestal)</small>
FX0	10-20	63 - 73	90 - 100	145-155
FX1	25-40	78 - 93	105-120	160-175
FX2	40-70		121-150	175-205
FX3	60-100			195-235
FX4	90-160			225-295
FX5	150-270			296-405
FX4-1	195-280			330-415
FX3-2	275-365			410-500
FX5-1	300-390			435-525
FX4-2	305-415			440-550
FX5-2	410-530			545-665

FX - (*) Refers to amount of extensions

TYPICAL 55/110PROFILE ARRANGEMENT LAYOUT



55Profile - (55x55)

110 Profile - (110x50)

JOIST ORIENTATION:



Flat side
UP
Decking



Flat side
DOWN
Tiling/Paving

BEARER ORIENTATION:



Flat side
UP

JOIST / BEARER LAYOUT (>150mm Height)

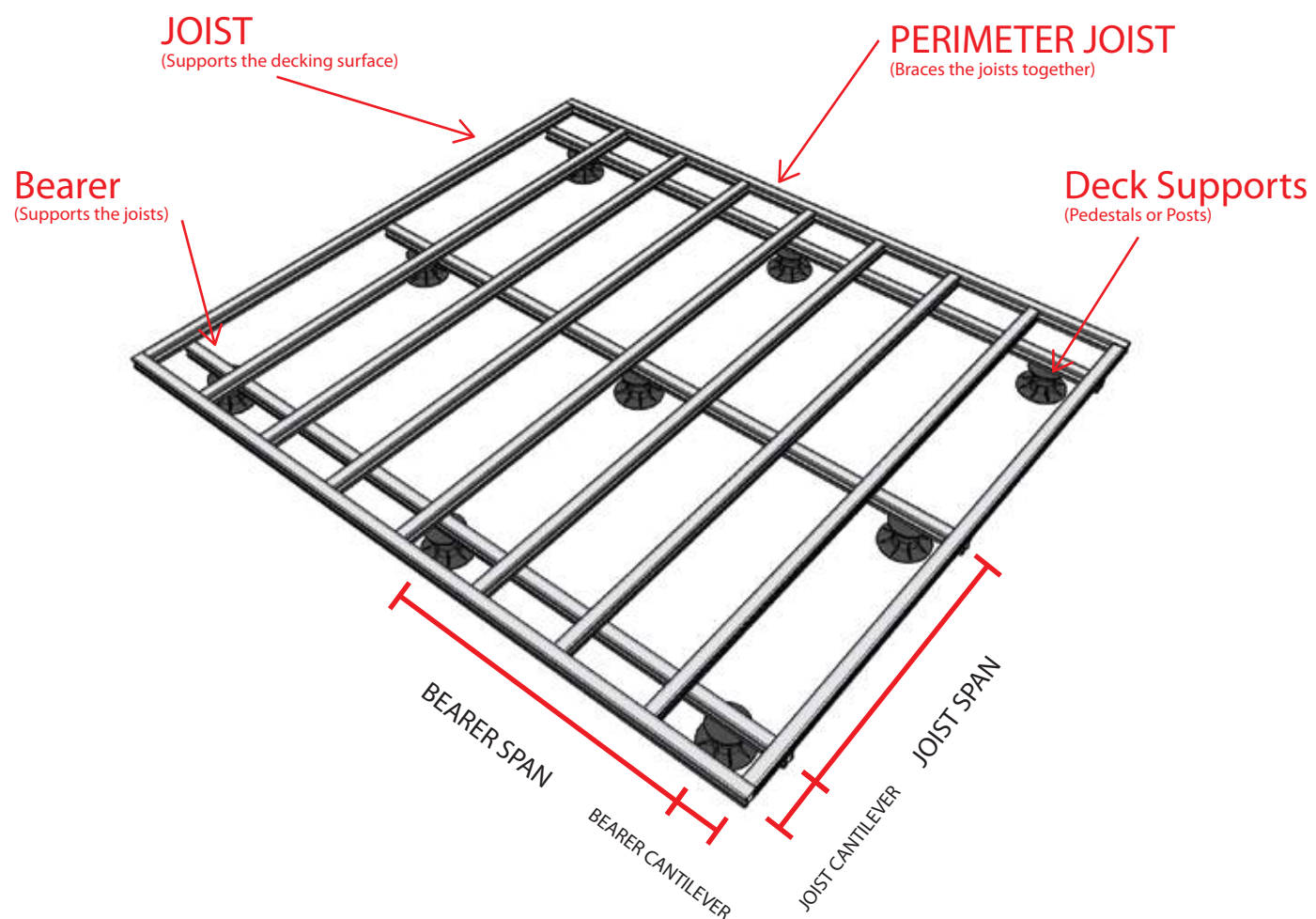

Height Layout

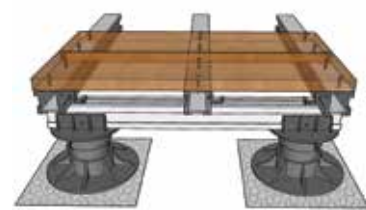
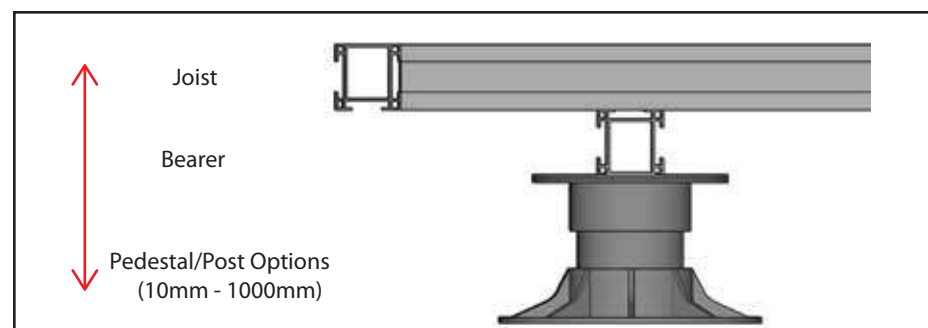

JOIST ONLY LAYOUT (<150mm Height)

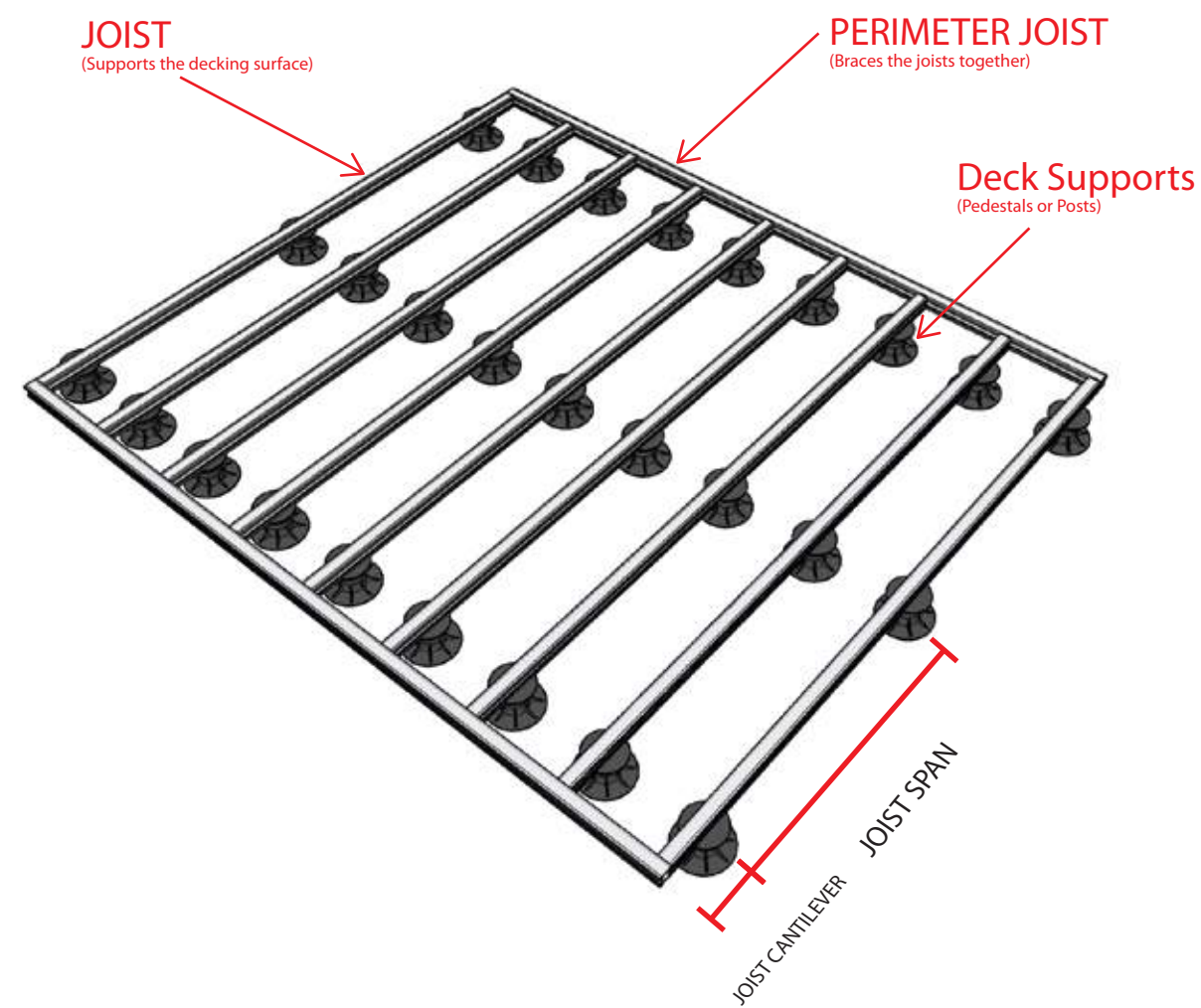

Height Layout

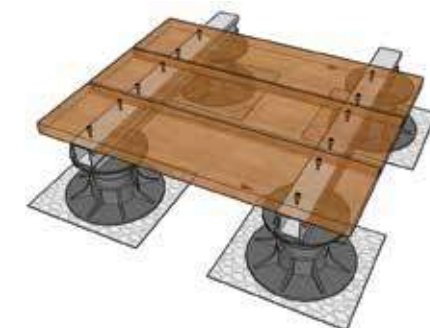
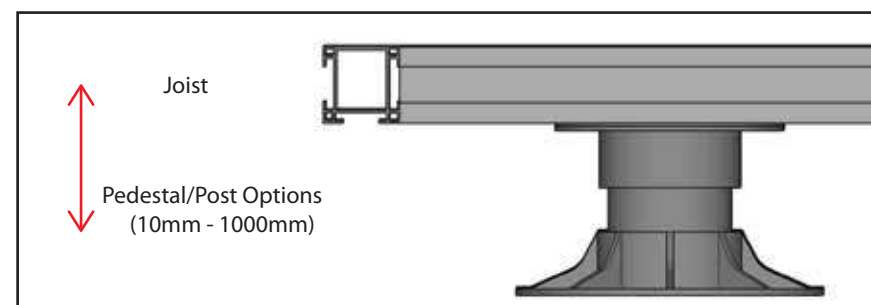

TYPICAL 55PROFILE ARRANGEMENT LAYOUT

JOIST OVER BEARER TYPICAL LAYOUT

FREESTANDING CONNECTION

JOIST ONLY TYPICAL LAYOUT

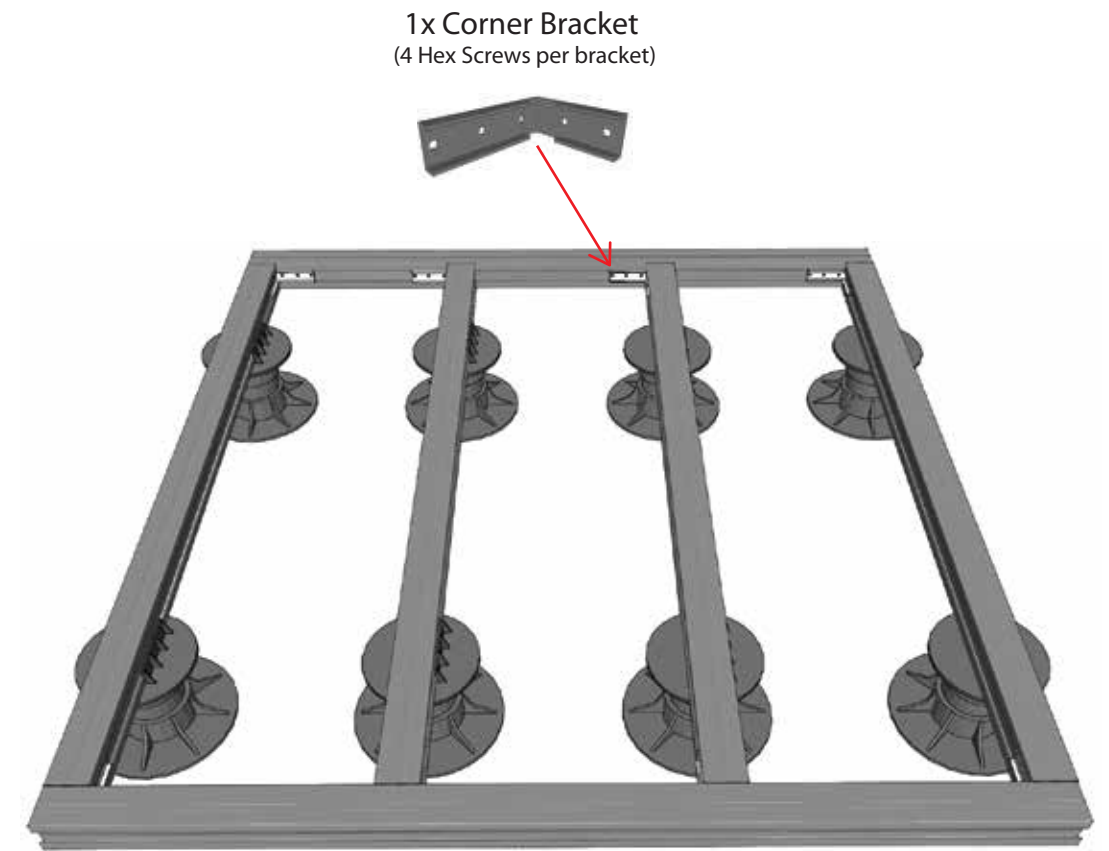
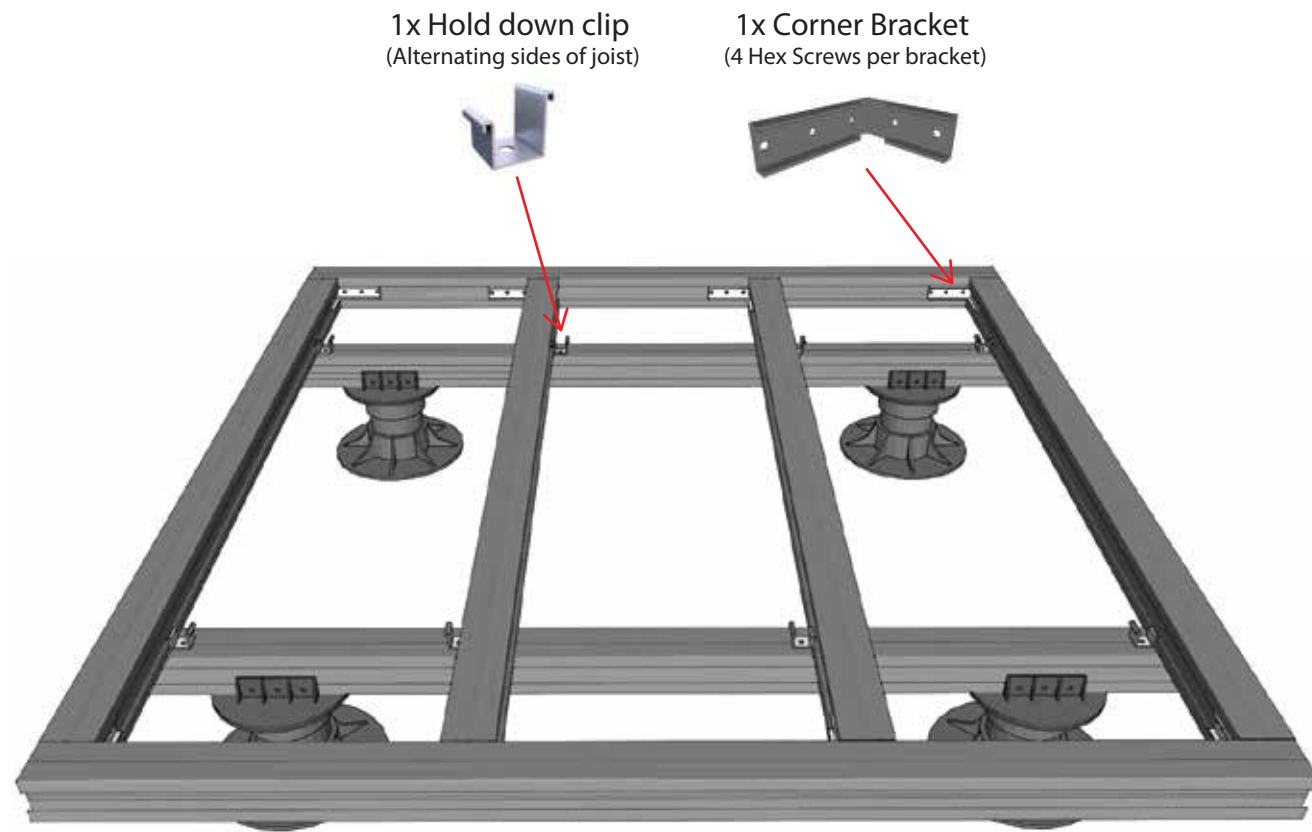

ATTACHING TO A STRUCTURAL WALL

LEDGER BOARD/ WAILING PLATE UNDER JOIST LAYOUT

Beam to be fastened to wall at 450mm intervals

LEDGER BOARD/ WAILING PLATE INLINE WITH JOIST LAYOUT

Beam to be fastened to wall at 450mm intervals

2x Corner Bracket
(4 Hex Screws per bracket)

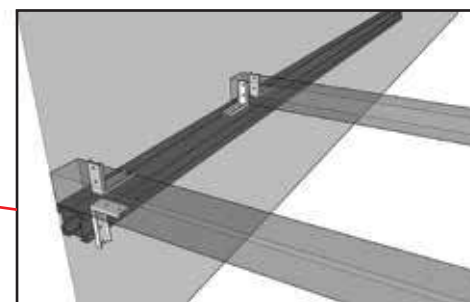
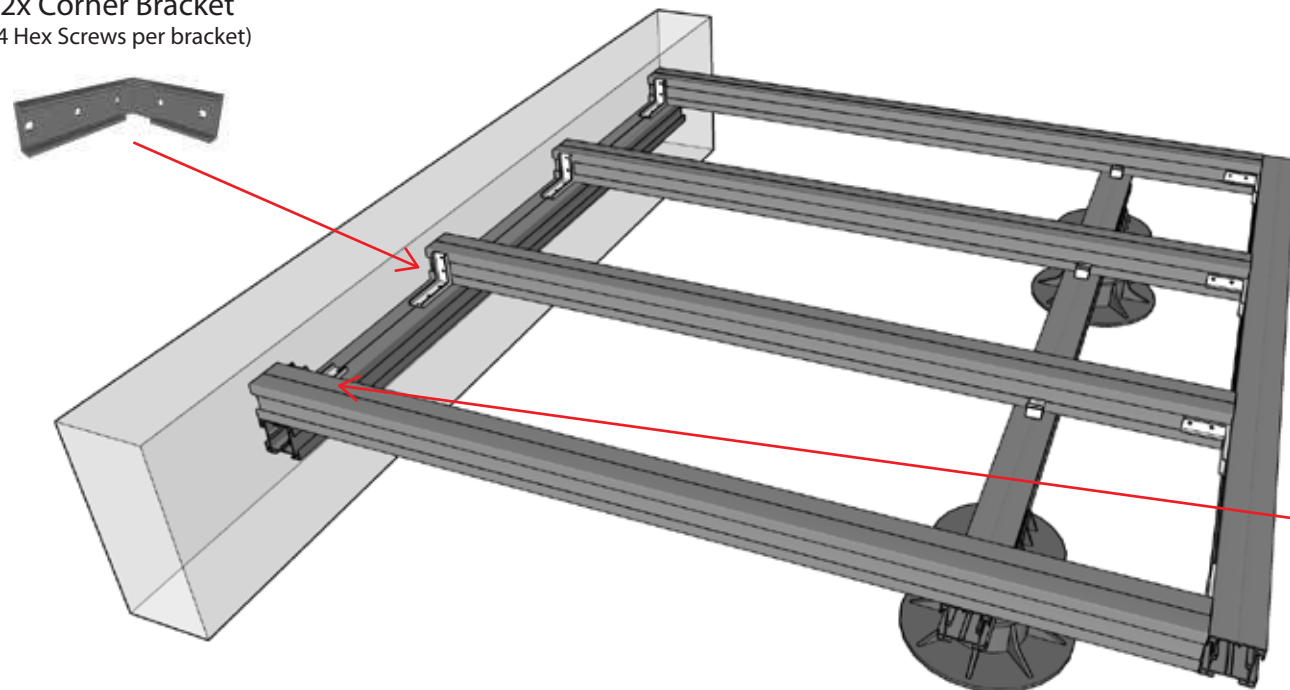

2 x Corner Brackets
(4 Hex Screws per bracket)

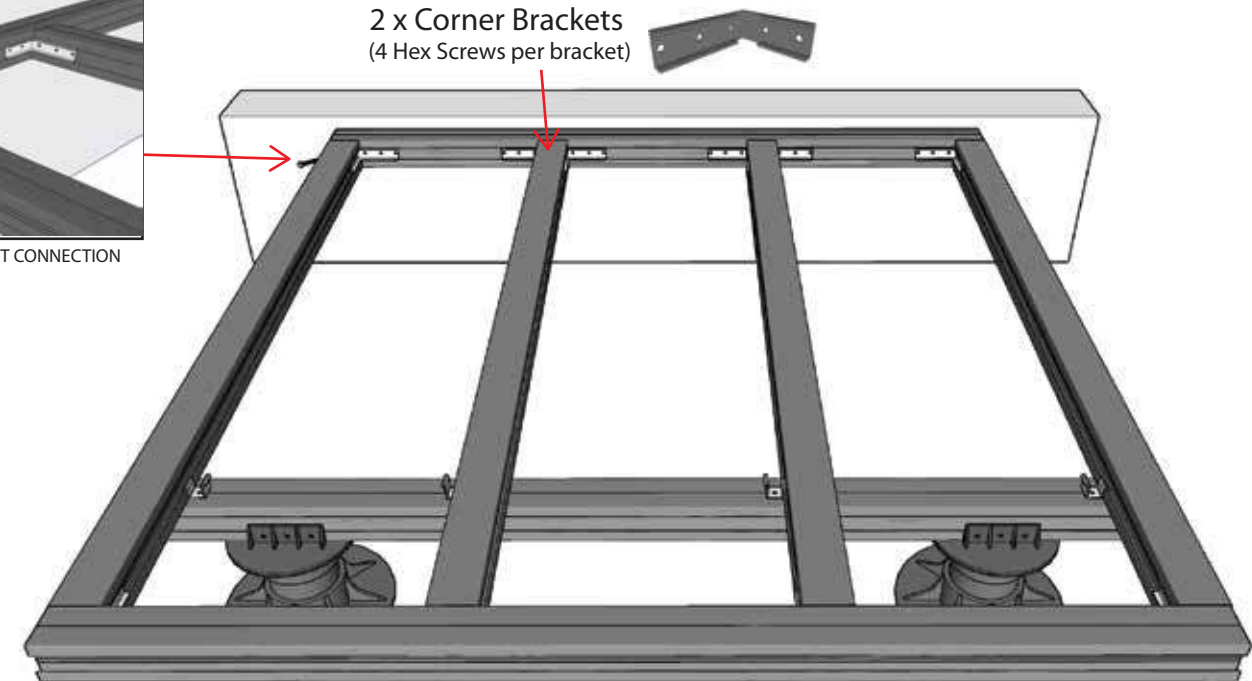

TYPICAL 28PROFILE ARRANGEMENT LAYOUT



28mm Profile

This profile can be used either flat side UP or DOWN



Corner bracket to make angled connections



28Profile Joiner to used to join the profile.



Can be used as a bearer for larger profiles.

Supporting the 28Profile - Packers



Predrill 28Profile
(Max 8mm diameter hole)

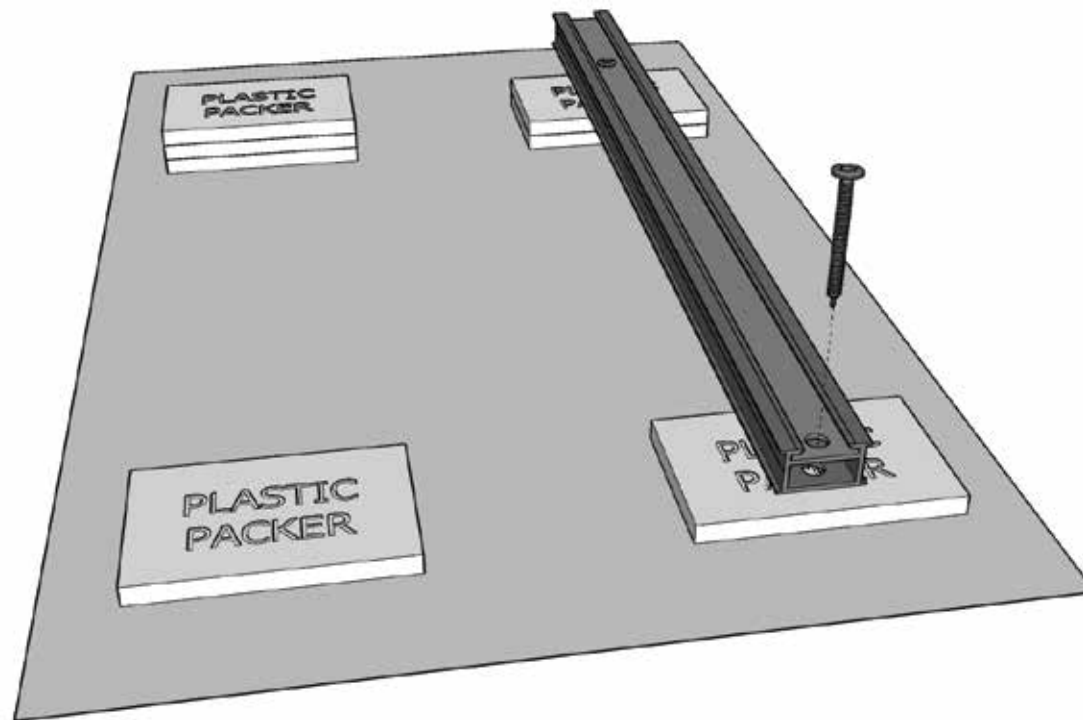

Use appropriate concrete fixings to secure the 28profile through the packer and into the concrete slab.

Please note: - Minimum 2mm clearance is required under 28profile

Supporting the 28Profile - Pedestals

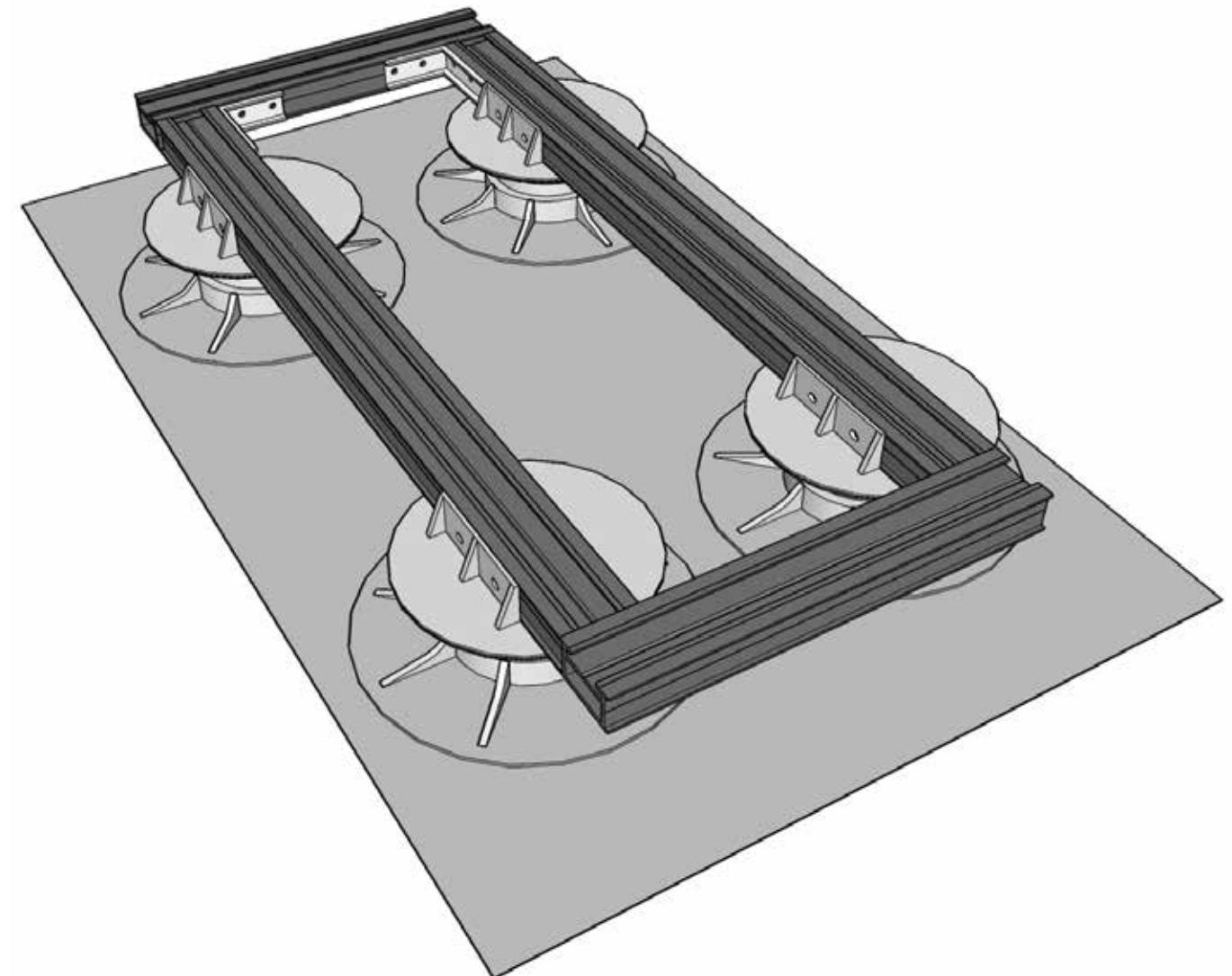

Clickdeck pedestal system can be used to support the 28profile, its recommended to use perimeter joists to brace the frame.

Hold down Clip

Used to hold down the Joist to the bearer.



1 Hex screw per clip

55 Profile



Insert hook into side of profile

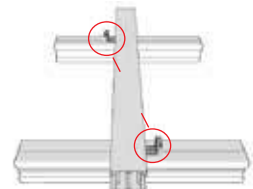

Install in alternating sides of joist

110 Profile

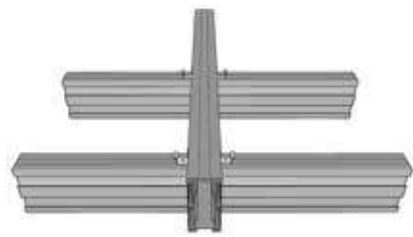

Install on both sides of joist

Corner Bracket

4 Hex screws per 90° Join
5 Hex screws per bent Join

55 Profile

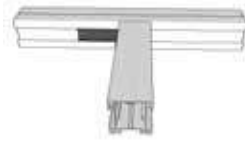

Joist to perimeter joist
(Non direct load bearing)



Bent to create angles



Joist to intergrated bearer
(2 Corner brackets)
Used when bearer is inline with Joist



Vertical Joins
(Allows fascia joists supports to be attached)

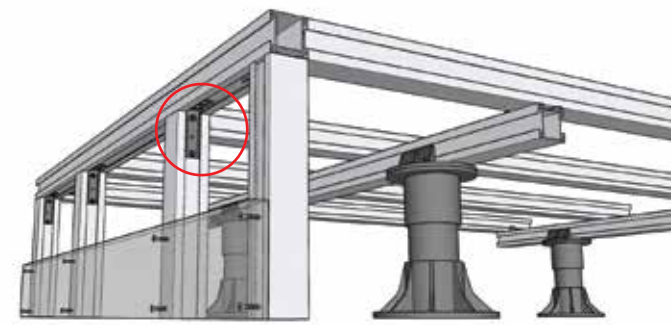

110 Profile



Joist to perimeter joist



Joist to perimeter joist
Non direct load bearing
(2 per join)

This connection is used
when a bearer is under the joist.



Joist to intergrated bearer
Load bearing connection
(4 per join)

This connection is used
when a bearer is inline with the joist.

Angled connection

Joist to angled perimeter joist

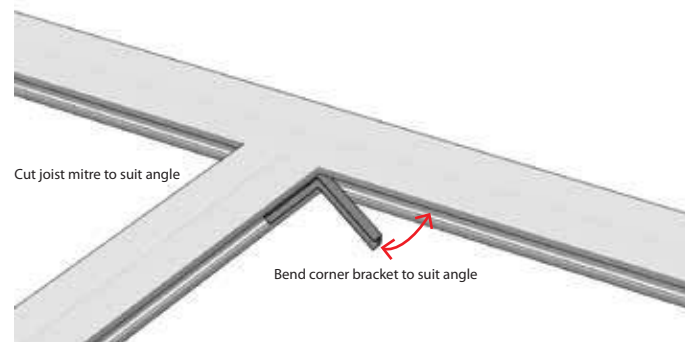

Cut joist mitre to suit angle

Bend corner bracket to suit angle

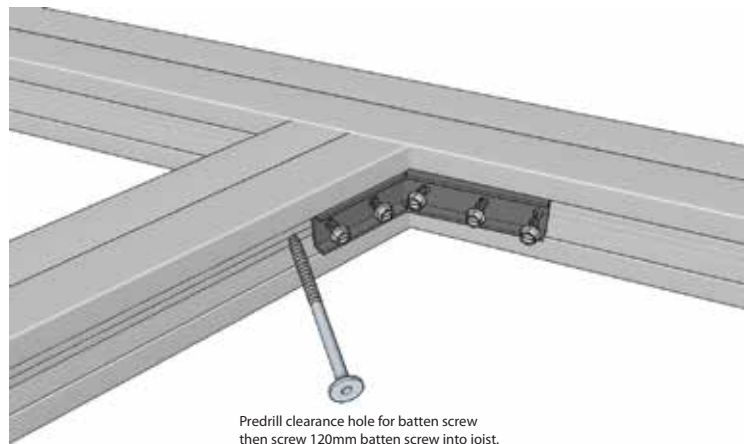

Predrill clearance hole for batten screw
then screw 120mm batten screw into joist.

Joiner

2 Joiners per Join
4x Hex screw per Joiner



55 Profile

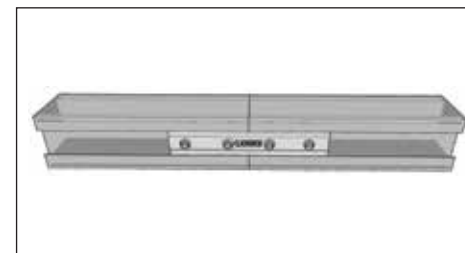
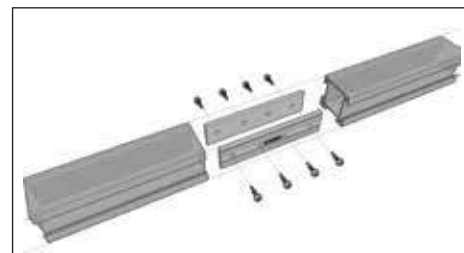

Recommended to have joiners within 400mm of supports

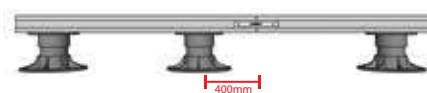

Joiners should **not** be placed on a load bearing cantilever



110 Profile

4 Joiners per Join
4x Hex screw per Joiner

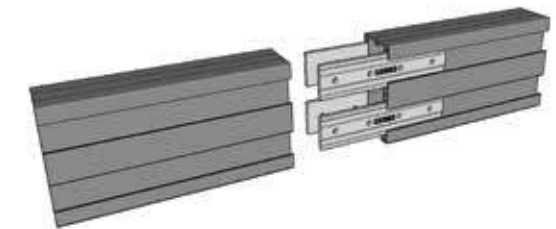

Clickdeck supplies the following options:

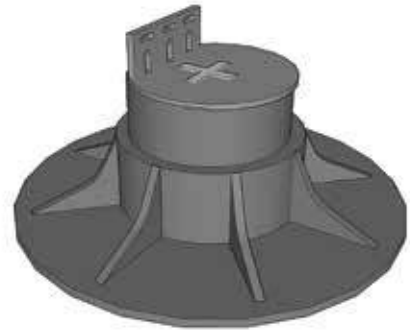

Clickdeck Pedestal

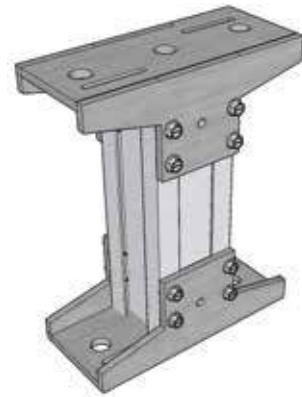

Clickdeck Aluminum Post kit

Pedestals on concrete pad footings

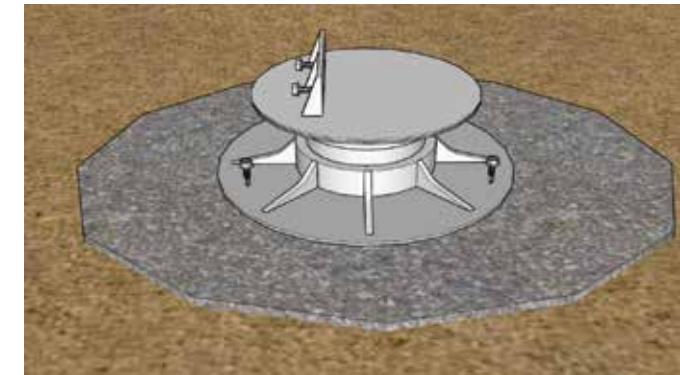

Pad footing (Typical detail)
- 350mm Diameter x Depth (Dependent on soil type)

Adjustable Pedestals

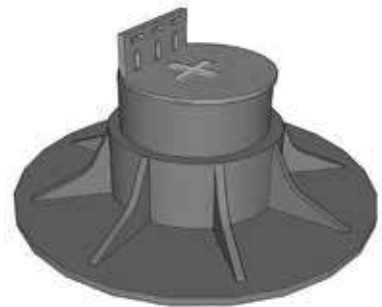

Pedestal Joist Head

Internal thread

Pedestal Base

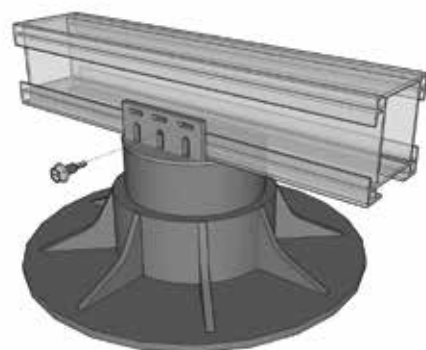

Fix joist head to aluminium profile (1 Hex screw)

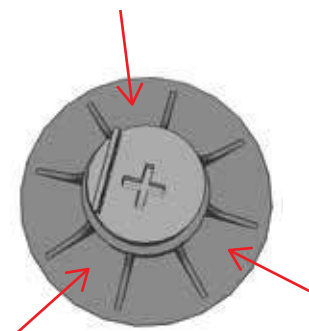

Pedestals can be fixed to ground by using masonry fixings eg, Nylon Anchors / Concrete Screws

Pedestal Selection table

Model Number	Pedestal Range <small>(All measurements are in millimeters)</small>	Finished Floor Height	
		<small>Including (Deckboard/Joist/Bearer/pedestal)</small>	<small>Including (Deckboard/Joist/pedestal)</small>
FX0	10-15	145-155	90 - 95
FX1	25-40	160-175	105-120
FX2	41-70	176-205	121-150
FX3	71-100	206-235	
FX4	101-160	236-295	
FX4-1	161-280	296-415	
FX5-1	281-390	416-525	
FX5-2	391-530	526-665	
FX5-3	631-634	666-769	
FX4-5	635-860	770-955	

FX - (*) Refers to amount of extensions

Aluminium Post

8 Hex Screws per post bracket
Max height of post - 600mm

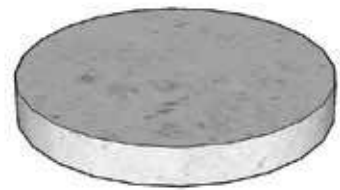
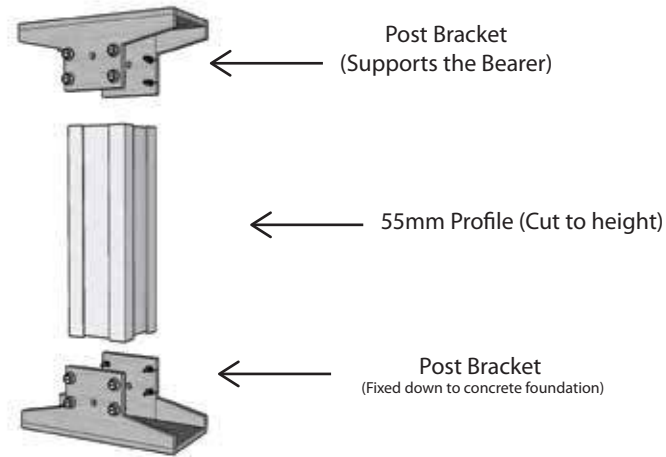
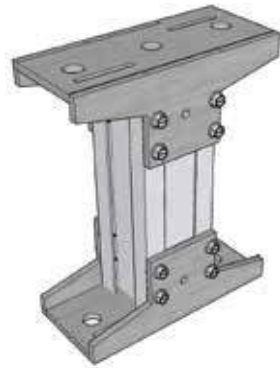

Suitable structural concrete foundation



Insulating packer or similar provide barrier between concrete and aluminium bracket

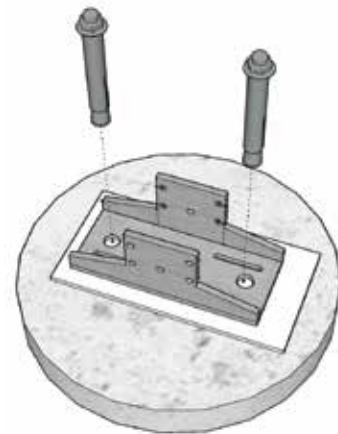

Using suitable masonry fixings attach post bracket to concrete foundation.

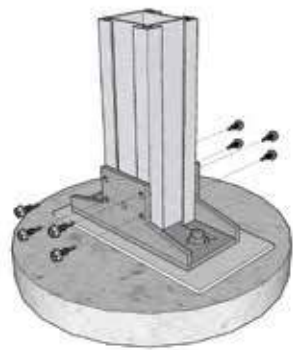

Insert 55mm Profile in bracket (Cut to desired height) secure profile with 8 hex screws

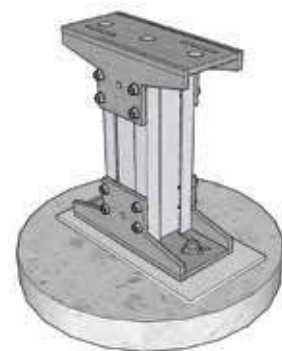

Secure top bracket with 8x hex screws

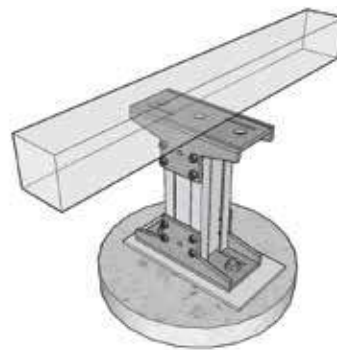

Place bearer onto post bracket

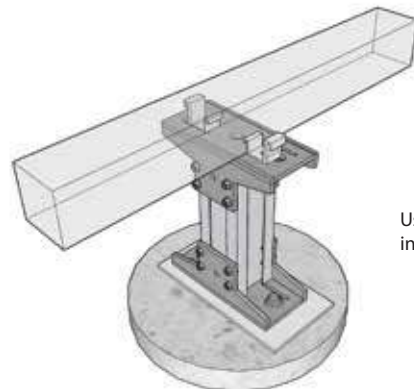

Using 2x Hold down clips, fasten hex screws into post bracket.

Note:

- All deck supports shall have a suitable structural foundation designed by a qualified professional.
- Rapid-set concrete or similar containing lime shall not be used when direct burying aluminium.
- Aluminium must be fully coated by barrier paint or similar and not be in direct contact with in-ground concrete.
- Maximum height for Aluminium post (55mm Profile) is 600mm from Ground level.
- Above 600mm height, a suitable timber or steel post maybe used.
- When attaching post bracket to concrete, an insulating packer or similar must be used to provide barrier between concrete and aluminium.
- It is recommended for the frame system to be attached to a perimeter wall or similar if possible.

Clickdeck can also be supported by:

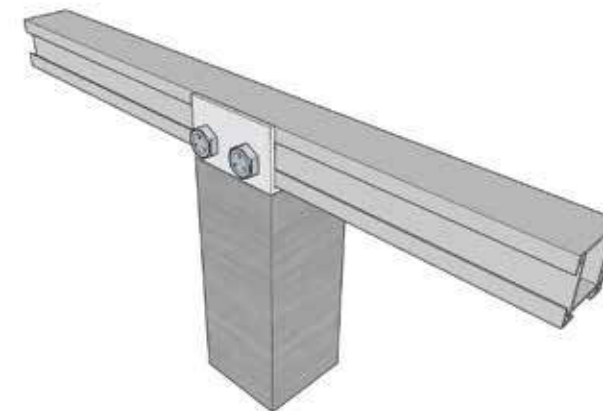

Steel Post

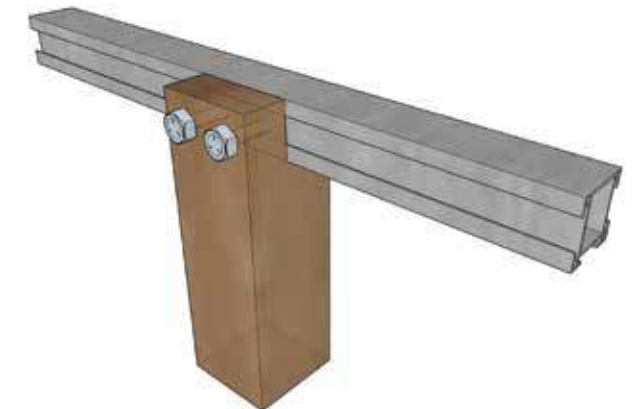

Timber Post

Standard



Breakerboard / Picture frame

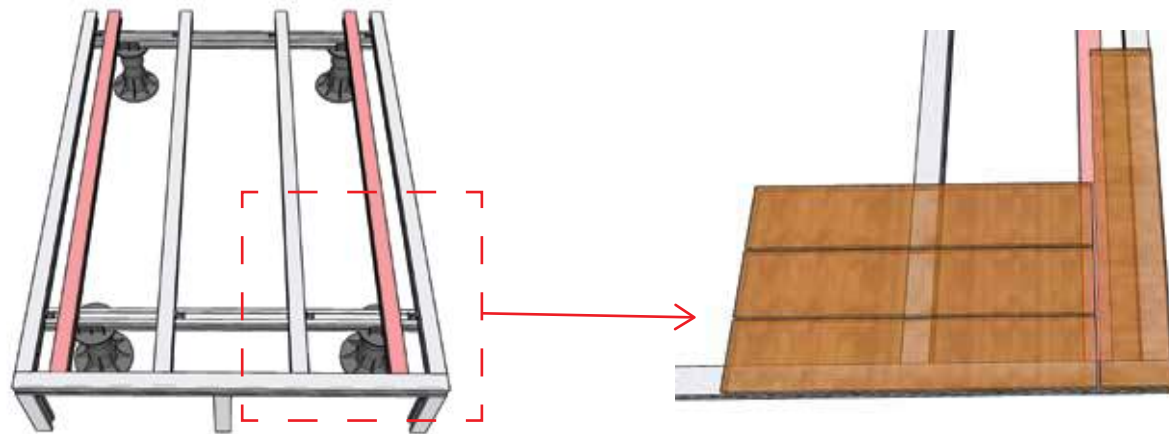

Add additional joists for picture frame

Obstructions - eg Pillars , pergola posts, downpipes ect.

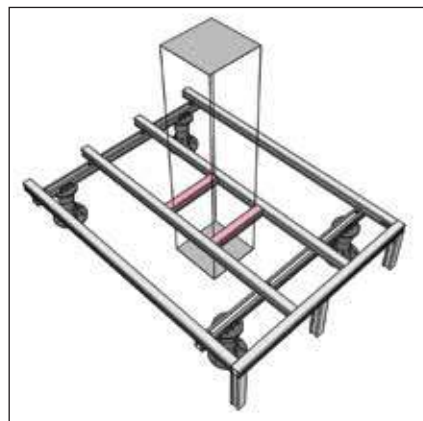

Add additional joists for supports around obstructions

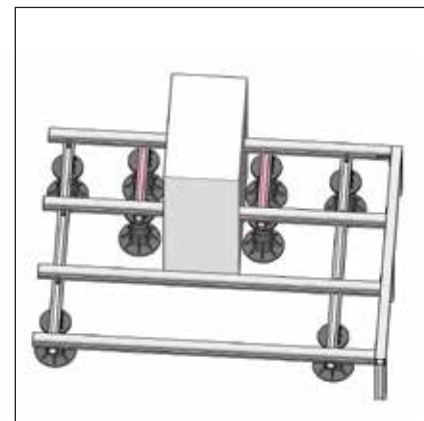
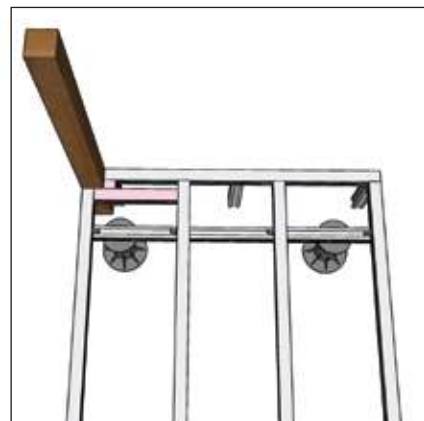

Add additional bearers and deck supports

Composite Decking

All fixings/screws are supplied by deckboard manufacturer, fixing instructions should be followed. Please consult manufacturer for recommended method.

Clickdeck is universally compatible with **all** brands of composite decking including:

EKODECK, TREX , AZEK (Timbertech) , MODWOOD, WOODEVO, BRITE DECK , POLIWOOD DECKORATORS, NEWTECHWOOD, FIBERON and many others.

Typical fixing methods:

STANDARD UNIVERSAL HIDDEN T-CLIPS



KLEVAKLIP STRIP



CAMO X EDGE METAL CLIP



COBRA CLIPS



Natural Timber Decking

Eg. Merbau, Spotted Gum ect.

Recommended:
Stainless steel metal drilling screws

Clickdeck stocks:



Anchormark Timber-to-Aluminium screws



Also compatible with all:
All universal type self drilling screw



Do not use screws with steel wings.

Alternative deck support methods

Bearer supported by timber post on stirrup.

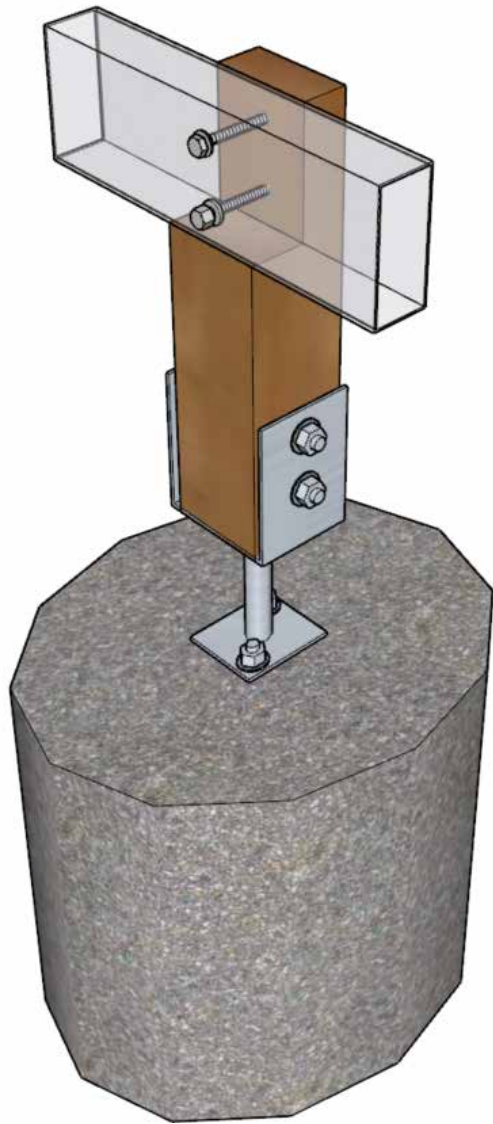

Bearer supported by timber post in concrete.

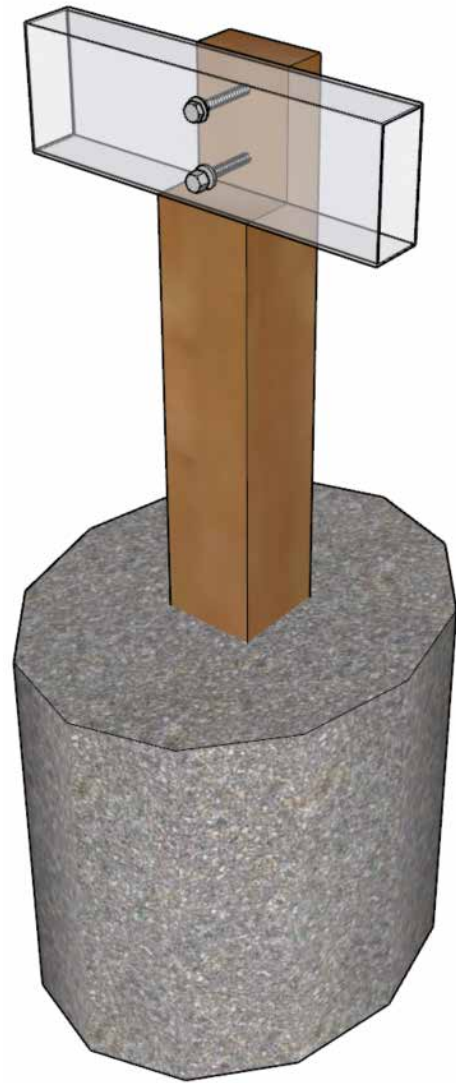

Bearer attached to (Typical ground screw)

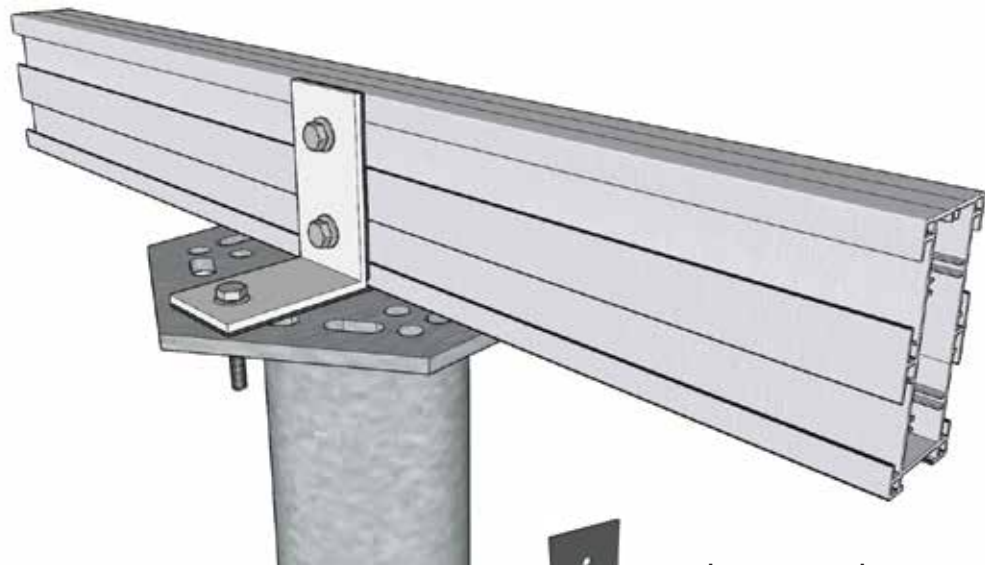

Insulating packer to separate aluminium to steel.

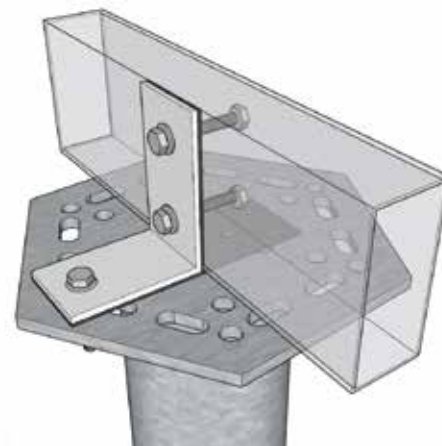

Steel post

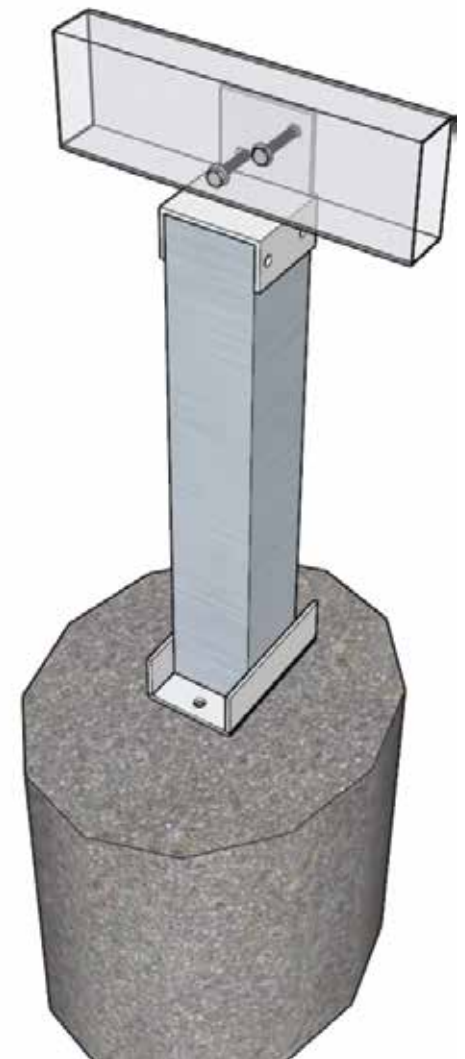
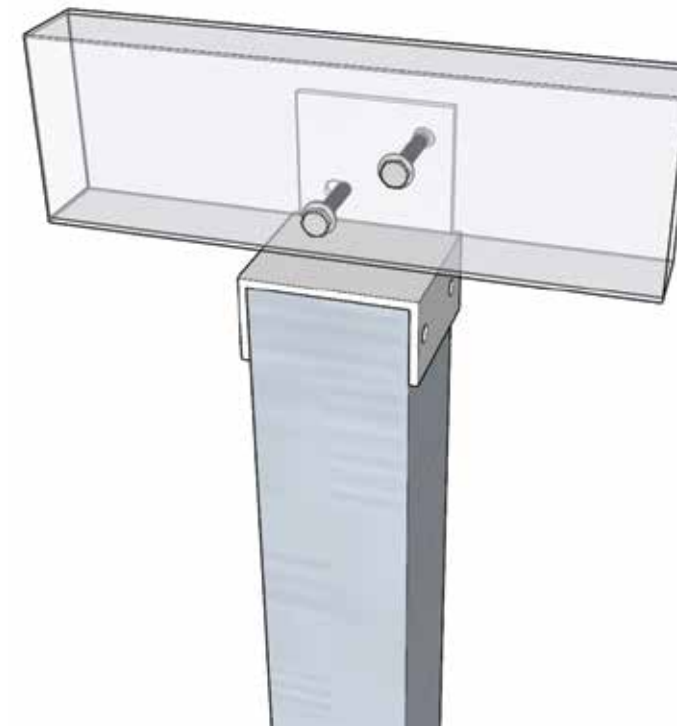

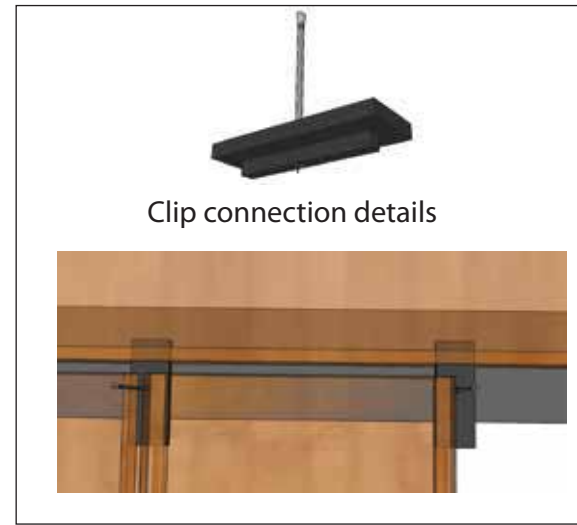
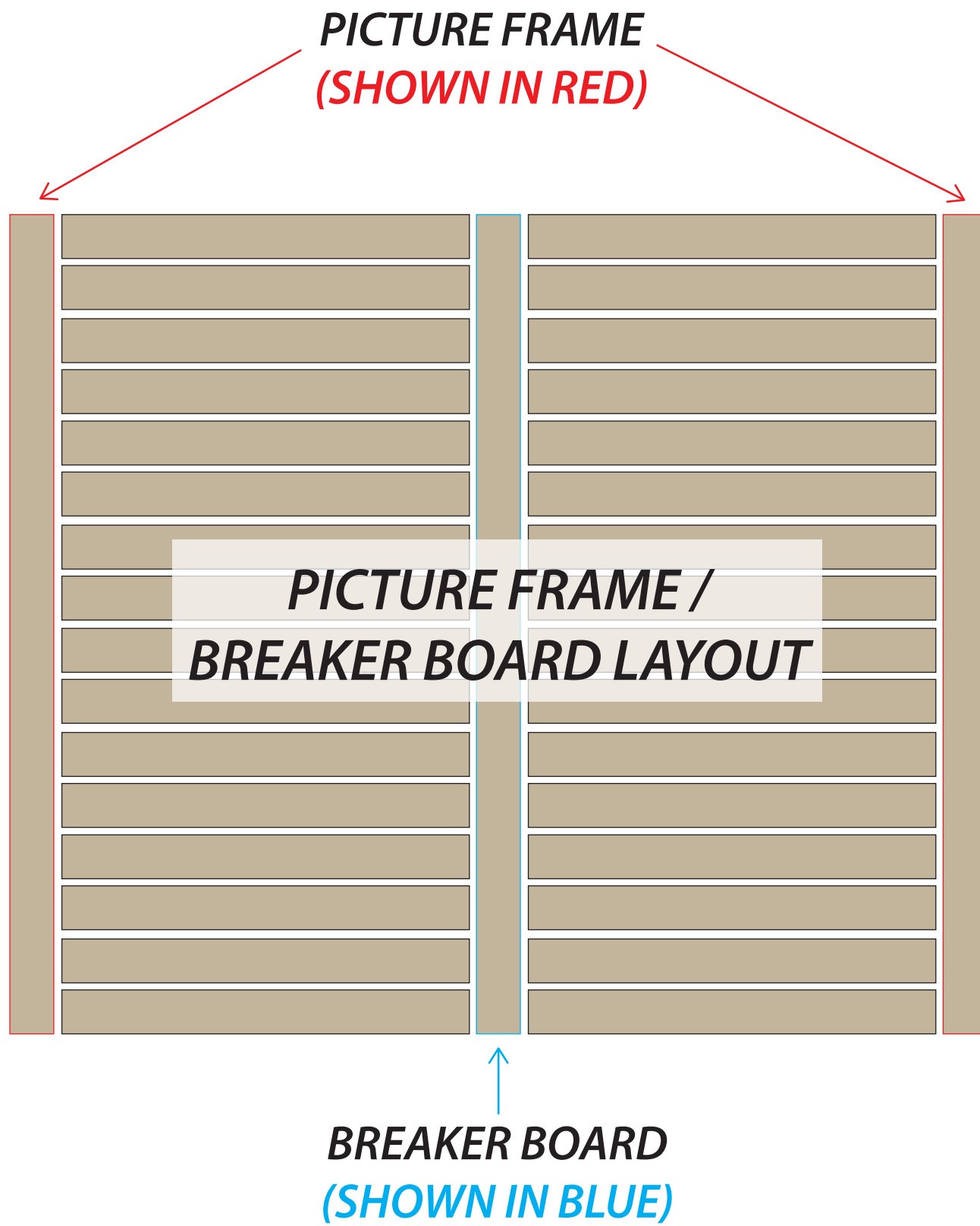

Breakerboard using 1x Additional joists



Breakerboard using 2x Additional joists

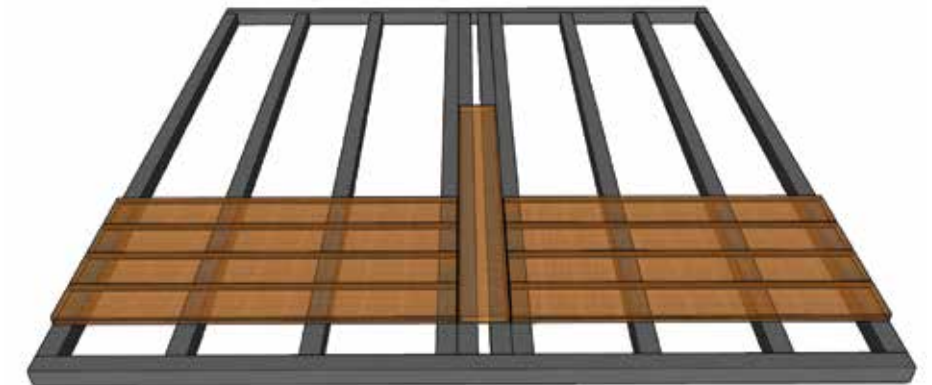

Picture frame using 1x Additional joist

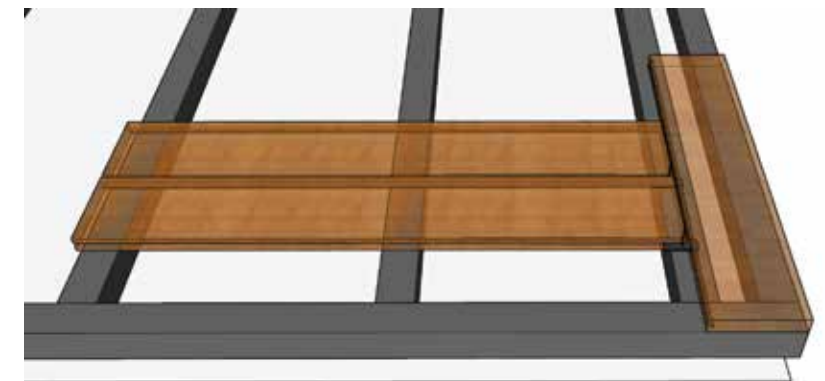

Picture frame using 2x Additional joists

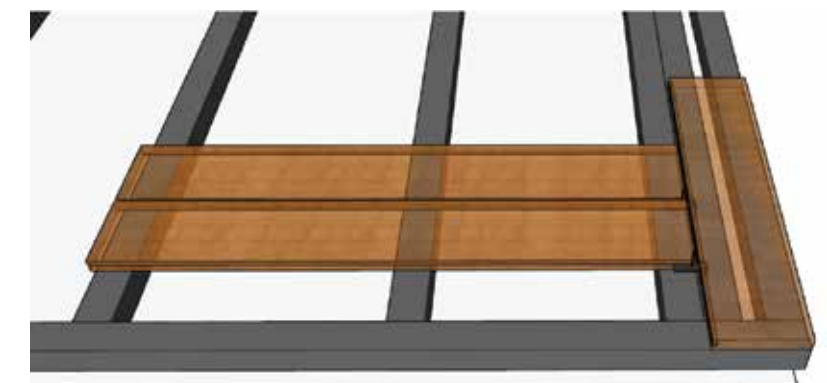

Curved Detail

For non supported edge

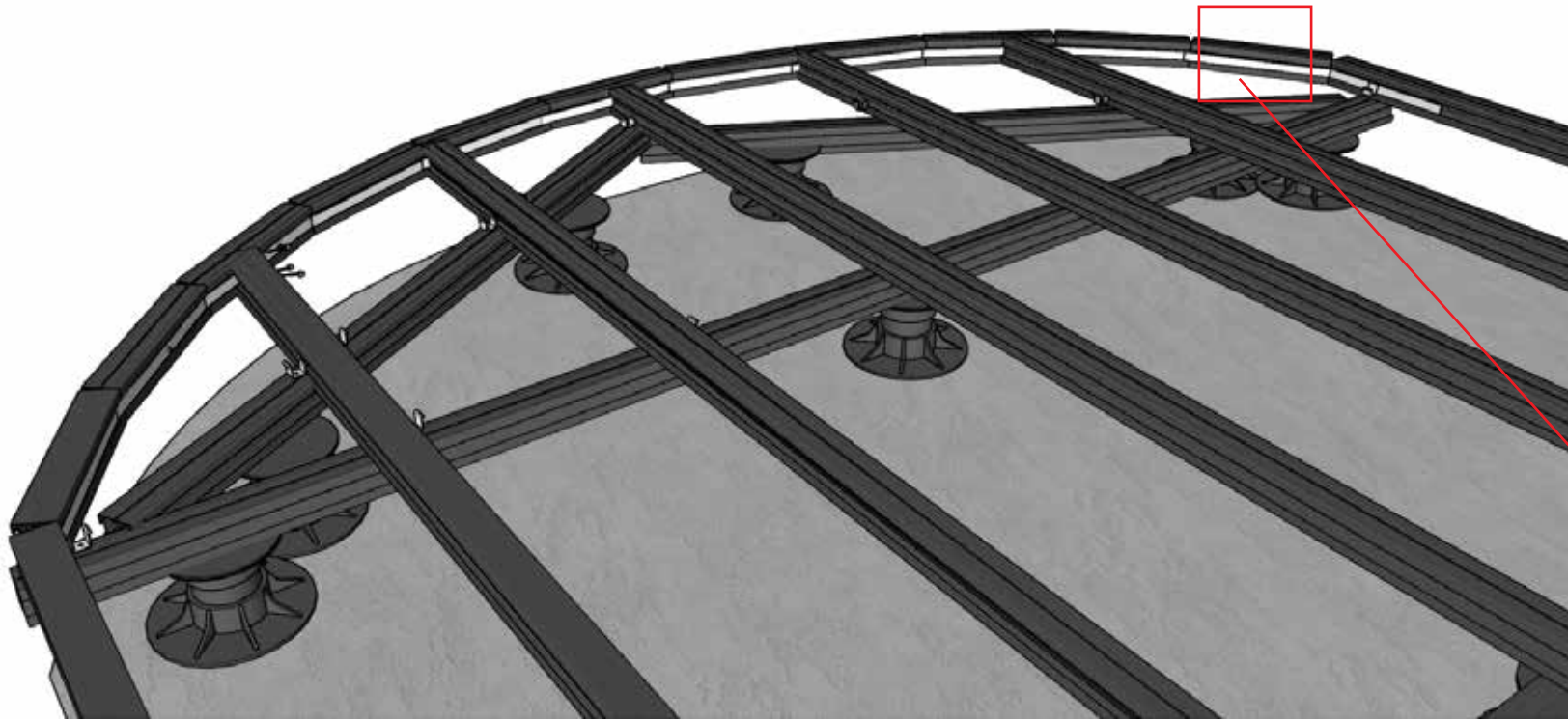

Step 1.

Slot out 80% of the joist profile depth, leaving 20% intact. Then bend to suit curve.



Step 2 . Reinforce the joist profile by using an aluminium strip (20mm x 1.6mm) fixed to the inside and outside of the perimeter joist. (If using flat side up)
Or
Only 1 internal strip needed if using profile flat side out



Step 3 .

To join joist to curved perimeter joist, cut joist to match angle, predrill 3x clearance holes through joist then screw longer hex screws through joist into perimeter joist.

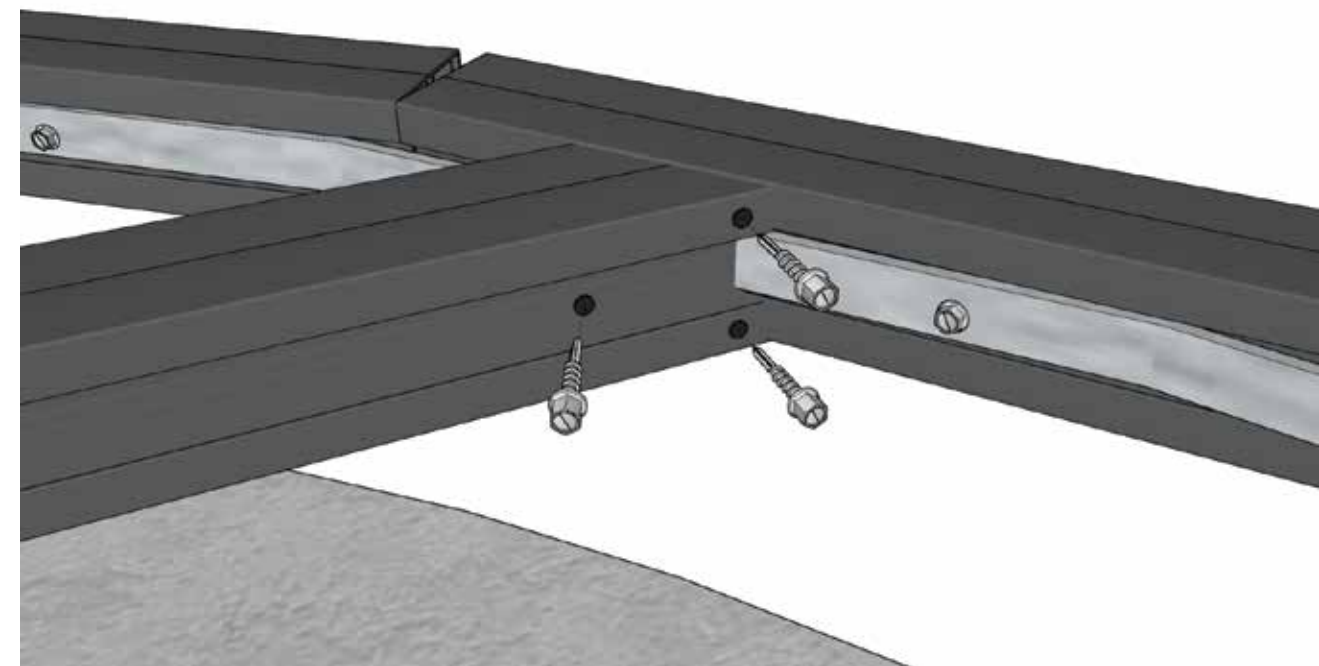

TILE / PAVER INSTALLATION

Clickdeck's raised paver solution is a fast easy way to raise floor levels whilst still allowing for a paved finish.

Pavers are typically 20mm or 30mm thick porcelain and are designed for raised applications, please consult paver manufacturer for suitability.

TILE RETAINER CLIP

Tile retainer clips are used to ensure tiles/pavers are firmly kept from sliding and moving off the frame.

These are used typically at each intersection of pavers along the perimeter of the frame, they can also be used internally to further reduce any movement.

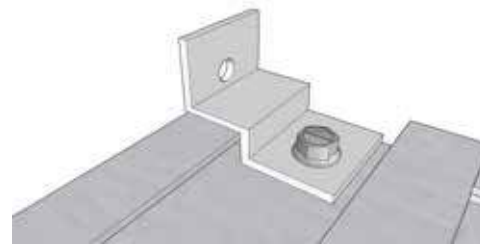
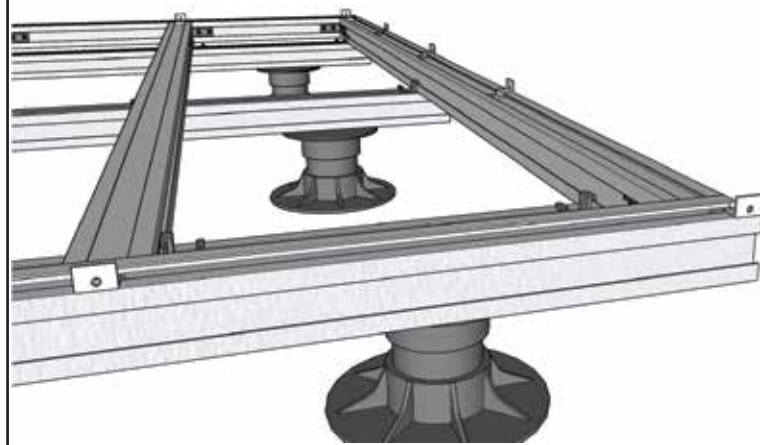
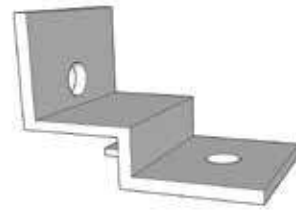

RUBBER TILE STRIP

For all installations where tiles/pavers are laid on the clickdeck system, our rubber tile strip is used to provide a non slip surface and noise barrier between the aluminium and pavers.

This simply press fits into the recessed channel as show below.

This is inserted for all joists and perimeter joists .



JOIST ORIENTATION:



Flat side
UP
Decking



Flat side
DOWN
Tiling/Paving

TILE SPACERS

Tile spacers are used at the intersections of the pavers to keep a uniform spacing.

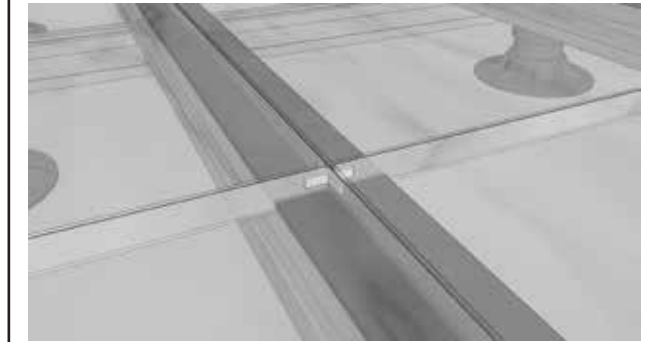
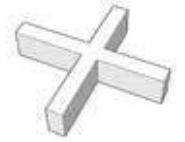

Fascia support for tiles/pavers

Attach corner brackets to underside of perimeter joists and external joists.

Tip: If building a low height deck, attach your brackets before assembling frame system.

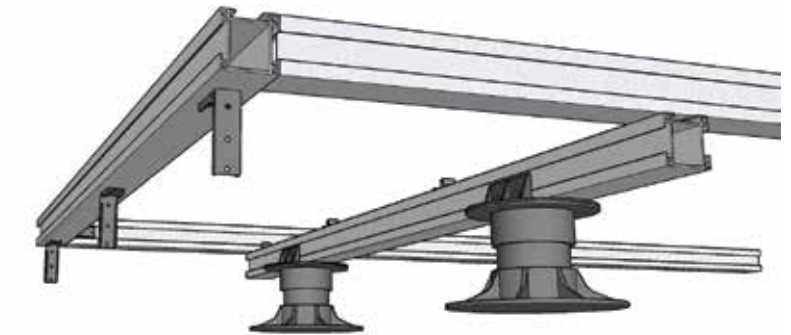

Cut a short length of the 55mm profile to create the fascia support, you can then attach tile retaining clips to assist the weight of the tile.

These tiles must be glued using tile glue.

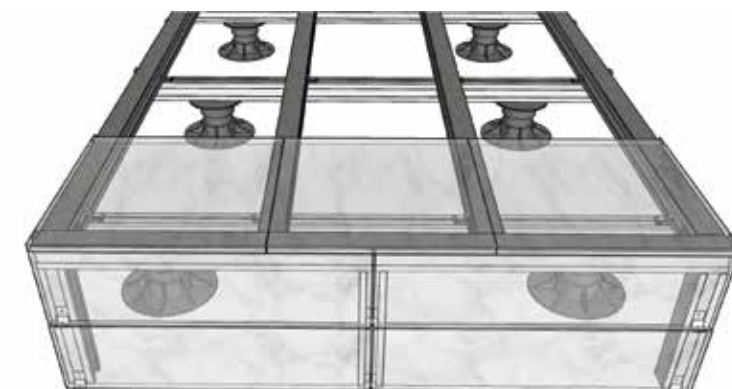
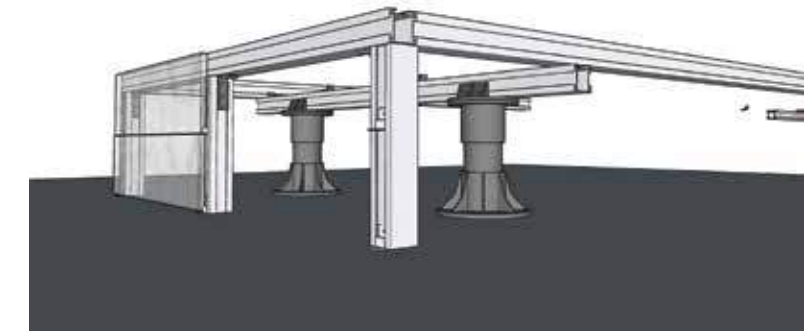

Using timber blocking

Please consult handrail manufacturer / structural engineer for site specific connection detail.

